

MP Series C TT/TNC/IT/TNS 40kA

电涌保护器 2级/Class C

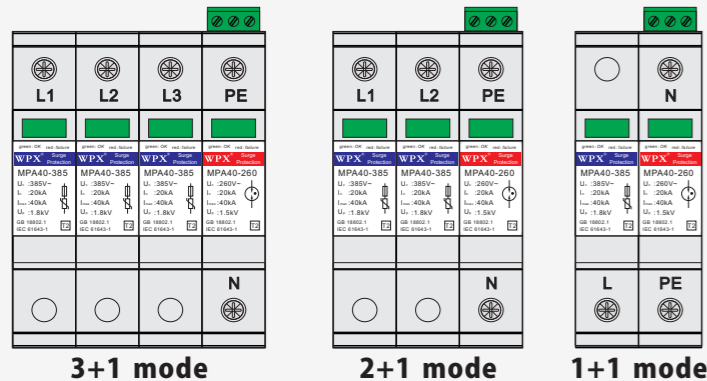

- 遥信功能;
- 通流量大, 残压低;
- 具有过热保护;
- 具有工作、失效指示;
- 外壳防护等级为IP20, 阻燃等级为UL94 V0

✦ Failure indication and centralized remote signalling alarm dry contacts;

✦ IP20, UL94 V0

- ✦ Intensity of Remote Signalling Alarm Contact;
- ✦ High discharge capacity and low residual voltage;
- ✦ Overtemperature protection, Class C protection;

型号	Model Number	3+1 mode	WPX-MPA40-440/3+N-FM	WPX-MPA40-440/3+N
货号	Art No.		941 206	941 216
型号	Model Number	2+1 mode	WPX-MPA40-440/2+N-FM	WPX-MPA40-440/2+N
货号	Art No.		931 206	931 216
型号	Model Number	1+1 mode	WPX-MPA40-440/1+N-FM	WPX-MPA40-440/1+N
货号	Art No.		921 206	921 216

SPD根据	SPD according	IEC61643-11/EN 61643-111	Class II/Type 2	Class II/Type 2
适用系统	Applicable power supply system		TNC/TNS/TT/IT	TNC/TNS/TT/IT
保护模式	Modes of protection		L1/L2/L3-N,N-PE	L1/L2/L3-N,N-PE
标称工作电压	Rated Working Voltage Uo		230V/400V~/400V/690V~	230V/400V~/400V/690V~
最大持续运行电压	Max Continuous Operating Voltage Uc ( L-N )		440V~	440V~
最大持续运行电压	Max Continuous Operating Voltage Uc ( N-PE )		260V~	260V~
标称放电电流	Nominal Discharge Current In(8/20μs) (L-N)		20kA	20kA
最大放电电流	Max Discharge Current In(8/20μs) (L-N)		40kA	40kA
标称放电电流	Nominal Discharge Current In(8/20μs) (N-PE)		20kA	20kA
最大放电电流	Max Discharge Current In(8/20μs) (N-PE)		40kA	40kA
5kA时, 电压保护水平	5kA, Voltage Protection Level Up(L-N)		≤1.7kV	≤1.7kV
10kA时, 电压保护水平	10kA, Voltage Protection Level Up(L-N)		≤1.85kV	≤1.85kV
电压保护水平	In Voltage Protection Level Up(L-N)		≤2.0kV	≤2.0kV
电压保护水平	Voltage Protection Level Up(N-PE)		≤1.5kV	≤1.5kV
响应时间	Response Time tA (L-N)		≤25ns	≤25ns
响应时间	Response Time tA (N-PE)		≤100ns	≤100ns
后备熔断丝	Max. mains-side Overcurrent Protection(L)		125A ( gL/gG )	125A ( gL/gG )
安装导线截面积(多芯)	Cross sectional area for wiring terminal connected to conductor		Stranded : 4~25mm <sup>2</sup>	Stranded : 4~25mm <sup>2</sup>
安装导线截面积(单芯)	Cross sectional area for wiring terminal connected to conductor		Solid Wire : 4~35mm <sup>2</sup>	Solid Wire : 4~35mm <sup>2</sup>
工作温度	Operating Temperature Range		-40°C...+80°C	-40°C...+80°C
相对湿度	Relative Humidity		≤95% ( 25°C )	≤95% ( 25°C )
大气压强	Atmospheric Pressure		86kPa...106kPa	86kPa...106kPa
工作频率	Working Frequency		42Hz...68Hz	42Hz...68Hz
扭矩: 接线端子/遥信	Torque: wiring terminal/remote signaling interface		2.5Nm/0.25Nm	2.5Nm
外壳材质	Enclosure material		合金塑料/UL V-0	合金塑料/UL V-0
安装形式	Mounting		DIN 35mm rail	DIN 35mm rail
防护等级	Degree of protection ( IP code)		IP20	IP20
遥信接口安装导线截面积	Max. Cross-sectional Area For Remote Signaling Interface		1.5mm <sup>2</sup>	——
遥信触点类型	Intensity of Remote Signalling Alarm Contact		AC:250V/ 0.75A 125V/ 3A	——
			DC : 30V/ 2A	——

电涌保护器 2级/Class C

MP Series C TT/TNC/IT/TNS 40kA

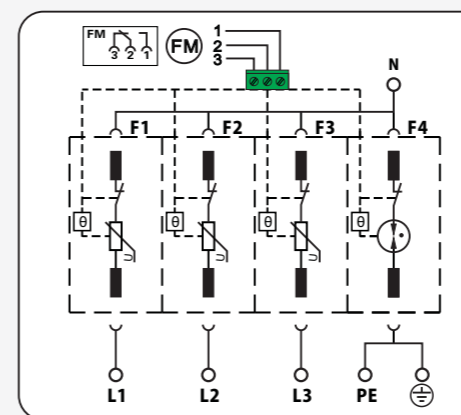

基本原理图 (Circuit Diagram)  
3+1 mode

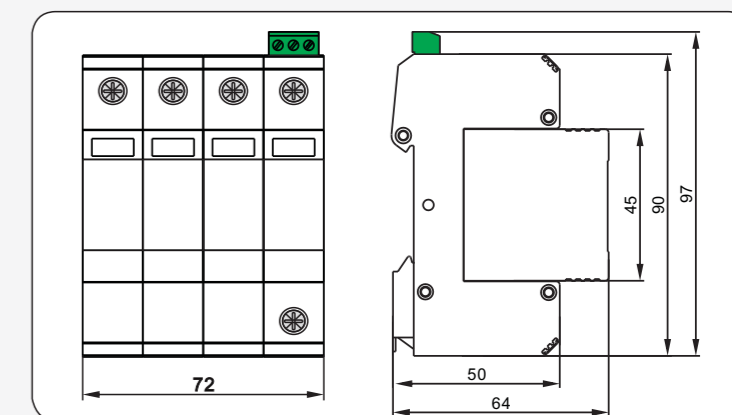

外形尺寸(Dimension):mm  
3+1 mode (L×W×H)(FM) : 72mm×97mm×65mm  
2+1 mode (L×W×H)(FM) : 54mm×97mm×65mm  
1+1 mode (L×W×H)(FM) : 36mm×97mm×65mm

WPX-MPA40-385/3+N-FM	WPX-MPA40-385/3+N	WPX-MPA40-320/3+N-FM	WPX-MPA40-320/3+N
941 205	941 215	941 204	941 214
WPX-MPA40-385/2+N-FM	WPX-MPA40-385/2+N	WPX-MPA40-320/2+N-FM	WPX-MPA40-320/2+N
931 205	931 215	931 204	931 214
WPX-MPA40-385/1+N-FM	WPX-MPA40-385/1+N	WPX-MPA40-320/1+N-FM	WPX-MPA40-320/1+N
921 203	921 215	921 204	921 214
Class II/Type 2	Class II/Type 2	Class II/Type 2	Class II/Type 2
TNC/TNS/TT/IT	TNC/TNS/TT/IT	TNC/TNS/TT/IT	TNC/TNS/TT/IT
L1/L2/L3-N,N-PE	L1/L2/L3-N,N-PE	L1/L2/L3-N,N-PE	L1/L2/L3-N,N-PE
230V/400V~	230V/400V~	230V/400V~	230V/400V~
385V~	385V~	320V~	320V~
260V~	260V~	260V~	260V~
20kA	20kA	20kA	20kA
40kA	40kA	40kA	40kA
20kA	20kA	20kA	20kA
40kA	40kA	40kA	40kA
≤1.4kV	≤1.4kV	≤1.2kV	≤1.2kV
≤1.5kV	≤1.5kV	≤1.4kV	≤1.4kV
≤1.8kV	≤1.8kV	≤1.6kV	≤1.6kV
≤1.5kV	≤1.5kV	≤1.5kV	≤1.5kV
≤25ns	≤25ns	≤25ns	≤25ns
≤100ns	≤100ns	≤100ns	≤100ns
125A ( gL/gG )	125A ( gL/gG )	125A ( gL/gG )	125A ( gL/gG )
Stranded : 4~25mm <sup>2</sup>	Stranded : 4~25mm <sup>2</sup>	Stranded : 4~25mm <sup>2</sup>	Stranded : 4~25mm <sup>2</sup>
Solid Wire : 4~35mm <sup>2</sup>	Solid Wire : 4~35mm <sup>2</sup>	Solid Wire : 4~35mm <sup>2</sup>	Solid Wire : 4~35mm <sup>2</sup>
-40°C...+80°C	-40°C...+80°C	-40°C...+80°C	-40°C...+80°C
≤95% ( 25°C )	≤95% ( 25°C )	≤95% ( 25°C )	≤95% ( 25°C )
86kPa...106kPa	86kPa...106kPa	86kPa...106kPa	86kPa...106kPa
42Hz...68Hz	42Hz...68Hz	42Hz...68Hz	42Hz...68Hz
2.5Nm/0.25Nm	2.5Nm	2.5Nm/0.25Nm	2.5Nm/0.25Nm
合金塑料/UL V-0	合金塑料/UL V-0	合金塑料/UL V-0	合金塑料/UL V-0
DIN 35mm rail	DIN 35mm rail	DIN 35mm rail	DIN 35mm rail
IP20	IP20	IP20	IP20
1.5mm <sup>2</sup>	——	1.5mm <sup>2</sup>	——
AC:250V/ 0.75A 125V/ 3A	——	AC:250V/ 0.75A 125V/ 3A	——
DC : 30V/ 2A	——	DC : 30V/ 2A	——